

REV	ECN No.	DATE	REMARK
A	NEW	2018.03.06	NEW RELEASE
B	ECN1808001	2018.08.06	加标尺寸标注及增加剖视图

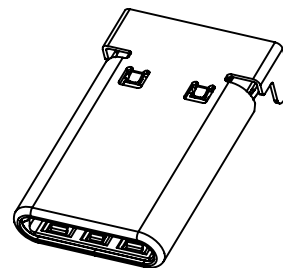

NOTE:

- MATERIAL SPECIFICATION:
 - HOUSING:HIGH TEMPERATURE RESISTANT PLASTIC,UL94 V-0.
 - CONTACTS:COPPER ALLOY
 - MID PLATE: STAINLESS (STEEL SUS301)
 - Hook: STAINLESS STEEL(STEEL SUS301)
 - SHELL: STAINLESS STEEL(STEEL SUS304)
- PLATING SPECIFICATION:
 - CONTACTS:
 - Ni 50u" MIN. UNDER PLATED OVER ALL.
 - Au PLATED ON THE FUNCTIONAL AREA OF CONTACT. (GOLD PLATING THICKNESS FOLLOW THE P/N)
 - SHELL:
 - Ni 30u" MIN. UNDER PLATED OVER ALL.
 - MID PLATE:
 - CLEAR ONLY
- MECHANICAL PERFORMANCE,
 - INSERTION FORCE: 0.5~2.0kgf.
 - REMOVAL FORCE: 0.8kgf~2.0kgf.
 - DURABILITY: 10000 CYCLES.
- ELECTRICAL PERFORMANCE,
 - CURRENT RATING:3.0A
VOLTAGE RATING:30V DC
 - LLCR:
 - VBUS & GND PINS AND OTHER PINS: 40mΩ/PIN MAX.
 - SHIELD: 50mΩ/MAX.
 - LLCR MAX. CHANGE OF ALL PINS: 10mΩ.
 - INSULATION RESISTANCE: 100MΩ MIN
 - DIELECTRIC WITHSTAND VOLTAGE,AC 100V FOR 1 MINUTE.
- ENVIRONMENTAL PERFORMANCE:
 - OPERATING TEMPERATURE: -30°C~+80°C.
- IR REFLOW:
 - THE PEAK TEMPERATURE ON THE BOARD SHALL BE MAINTAINED FOR 10 SECONDS AT 260°C.

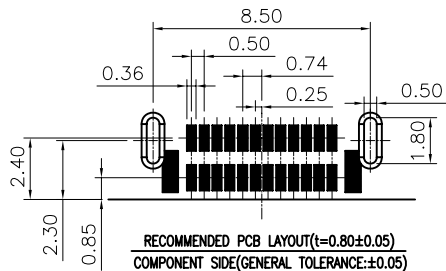
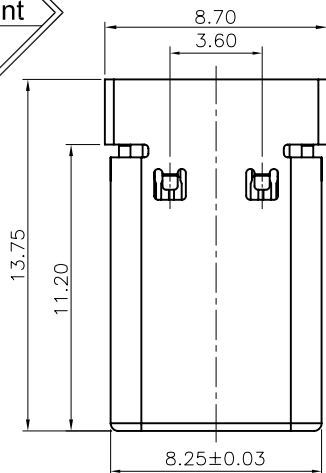
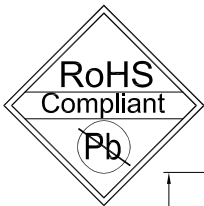
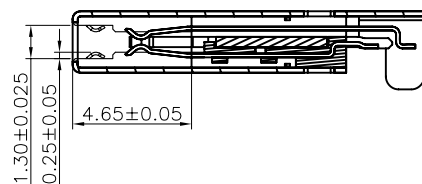
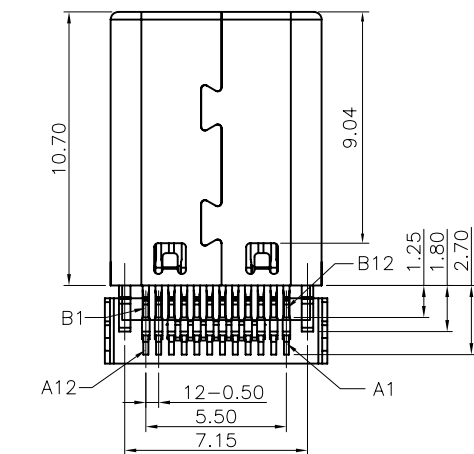
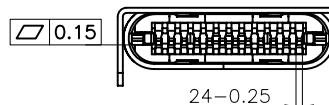
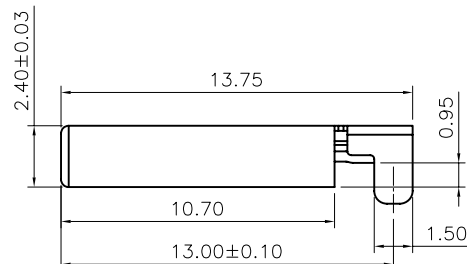
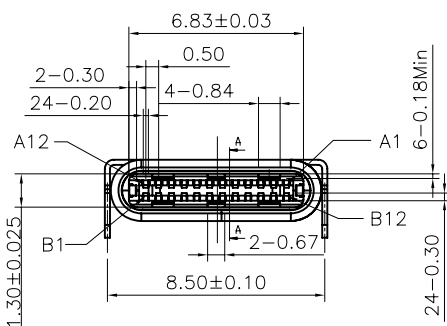

A1	GND	B12	GND
A2	SSTXP1	B11	SSRXP1
A3	SSTXN1	B10	SSRXN1
A4	VBUS	B9	VBUS
A5	CC1	B8	SBU2
A6	DP1	B7	DN2
A7	DN1	B6	DP2
A8	SBU1	B5	CC2
A9	VBUS	B4	VBUS
A10	SSRXN2	B3	SSTXN2
A11	SSRXP2	B2	SSTXP2
A12	GND	B1	GND
PIN	SIGNAL NAME	PIN	SIGNAL NAME

MATERIAL NO.:

SEE THE TABLE

REVIEW TABLE FOR DETAILS

QUALITY SYMBOL	GENERAL TOLERANCES (UNLESS SPECIFIED)
0	x.xxxxx ± ---
0	x.xxx ± 0.10
0	x.xx ± 0.25
0	x.x ± 0.30
0	ANGULAR ± ---

THIS DRAWING CONTAINS INFORMATION THAT IS PROPRIETARY TO ZDT TECHNOLOGY, AND SHOULD NOT BE USED WITHOUT WRITTEN PERMISSION

深圳市虹康科技有限公司

TITLE: USB TYPE C M 24PIN SMT CONNECTOR(双贴沉板0.95)

DRAWN BY: SAM DATE: 2018.08.06

CHECKED BY: JAY DATE: 2018.08.06

APPROVED BY: JACKY DATE: 2018.08.06

DOCUMENT NO. SHK-31398 SHEET NO. 1 OF 3

DIMENSION STYLE: MM ONLY DESIGN UNITS: METRIC SCALE: 5:1

THIRD ANGLE PROJECTION

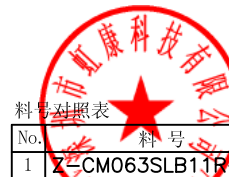

料号对照表

No.	料号	品名规格
1	Z-CM063SLB11F-A-03	Au:1u"LCP 黑色