

REV	LTR	DESCRIPTION	DATE	APPROVED
A0				

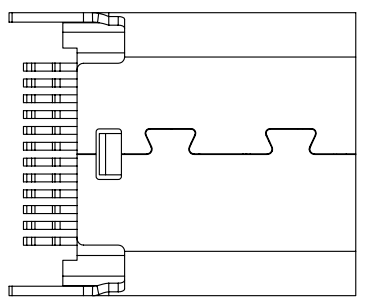
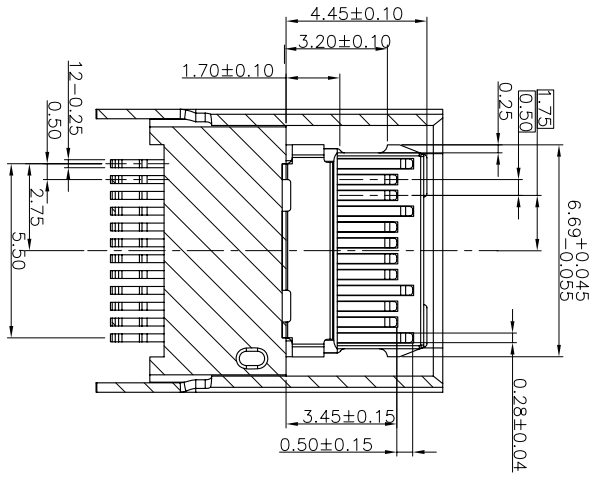
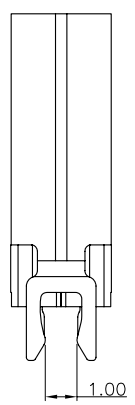
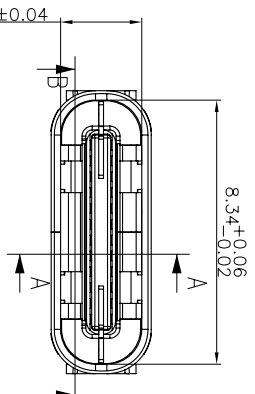
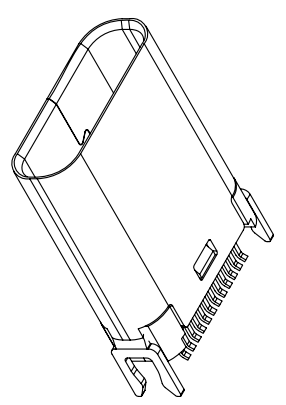
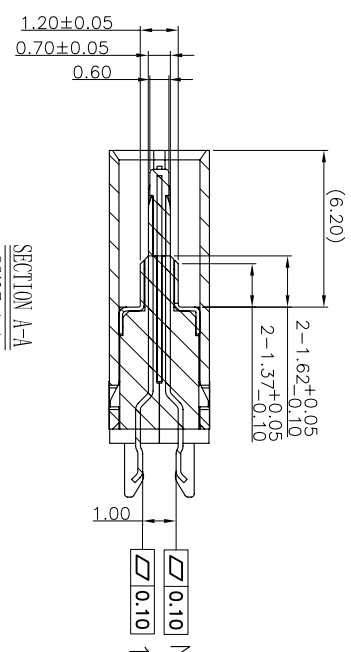
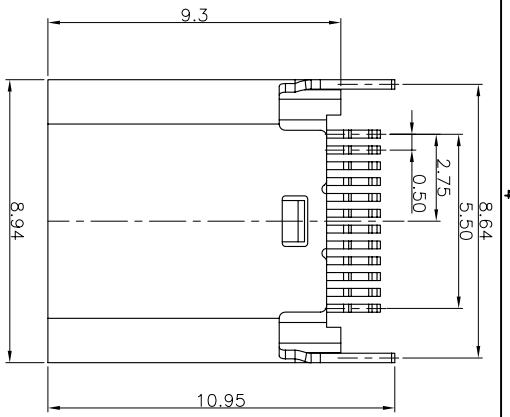

- NOTES:
- MATERIAL:  
MOLDING: LCP UL94 V-0  
CONTACT: COPPER ALLOY.  
GOLD PLATED 30u" Min ON CONTACT AREA, 100u" Min TIN (LEAD FREE) ON SOLDER AREA, 50u" NICKEL PLATING OVER ALL.
  - MECHANICAL:  
SHELL: SUS304-H,T=0.30±0.03mm  
50u" NICKEL PLATING OVER ALL.  
SHILD: SUS304-H,T=0.12±0.03mm
  - ELECTRICAL:  
CURRENT: 5A MIN FOR VBUS;  
0.25A MIN FOR OTHER.  
VOLTAGE: 5VAC MAX  
WITHSTANDING VOLTAGE: 100V AC.  
CONTACT RESISTANCE: 40mΩ MAX.  
INSULATION RESISTANCE: 100MΩ MIN.
  - ENVIRONMENTAL  
TEMPERATURE RANGE -55°C ~ +85°C

TOLERANCES
.X ±0.30
.XX ±0.20
.XXX ±0.10
ANGLES ±1.00°

TITLE: USB 3.1Type-C/180夹板1.0长9.30母座成品  
 PART NO.: SHK-31015C  
 APPD.:  
 CHECK: LTY  
 DRAWING NO.: 036-00\*

深圳市虹康科技有限公司

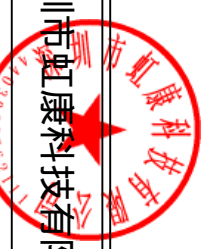

DRAWN:	REV:	SIZE:	UNIT:	SCALE:	SHEET:
LTY	A/0	A4	MM	1:1	1/1