

规格说明:Specifications:

电气特性:Electrical:

1. 额定电流: Current Rating  
1.5A/contact terminal
2. 额定电压: Voltage Rating  
30V DC
3. 接触阻抗:Contact Resistance  
30 milliohms MAX
4. 耐电压:Dielectnic Withstanding Voitage:  
500 V AC AT Sea Level
5. 绝缘阻抗:Lnsulation Resistance:  
1000MEGA ohms MIN

物理性能:Mechanical:

1. 插拔力: Cnnector Mate and Unmate Force  
Mate force:3.57kgf(MAX)  
Unmate force:1.02kgf(MIN)
2. 端子保持力: Terminal Retenion  
1.2kgf(MIN)

原材料:Material:

1. 塑胶:Housing:  
Hing Temperature Ternmaplastics,  
PBT White/Black
2. 端子>Contact:Copper Alloy C2680
3. 外壳:Shell: Copper Alloy C2680/SPCC

电镀:Finish:

1. 端子>Contact: Plated Gold in Mating Area;  
Tin On Solder Talls
2. 外壳:Shell:  
Nickel Plating

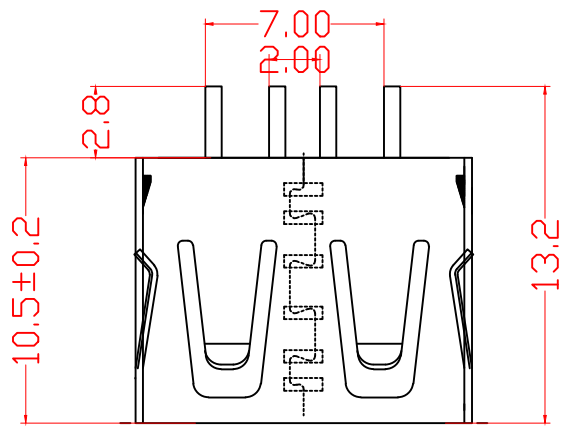
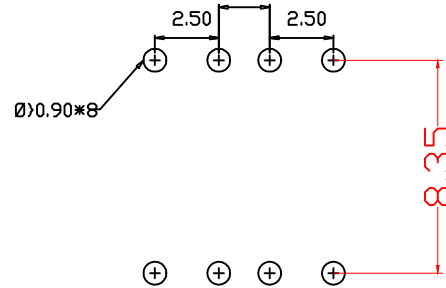
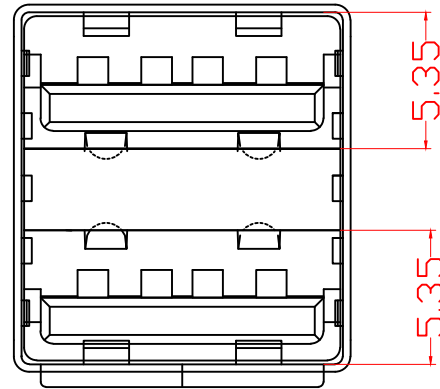
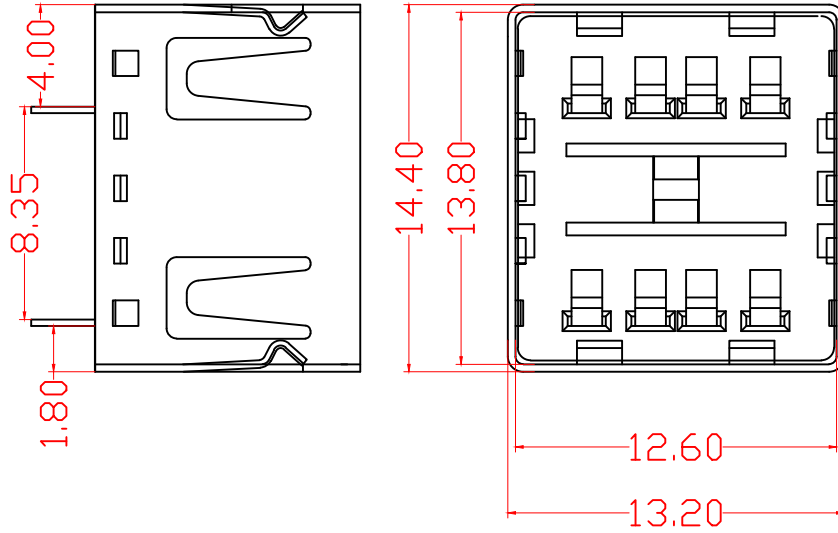

RBCOMMENDBD P.C.B PATTBRN LAY  
OUT

深圳市虹康科技有限公司

|                                      |       |                                   |       |                 |          |                             |      |
|--------------------------------------|-------|-----------------------------------|-------|-----------------|----------|-----------------------------|------|
| UNLESS OTHERWISE SPECIFIED TOLERANCE |       | RBCOMMENDBD P.C.B PATTBRN LAY OUT |       | DRAWN H.Q.huocy |          | TITLE USB AF 双层直插10.5MM无脚直边 |      |
| .X                                   | ±0.20 | APPROVED                          | UNIT  | MM              | PART NO. | SHK-20127                   | REV. |
| .XX                                  | ±0.15 | DATE                              | SCALE | 3/1             | DOC. NO. |                             | A    |
| .XXX                                 | ±0.10 | 2011.03.18                        | SIZE  | A4              |          |                             |      |
| ANG.                                 | ±2°   |                                   |       |                 |          |                             |      |