

REV.	ECH. NO.	APPD.
A	/	pcy

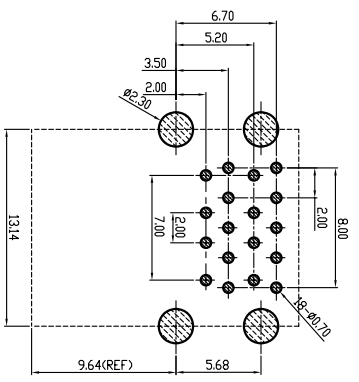
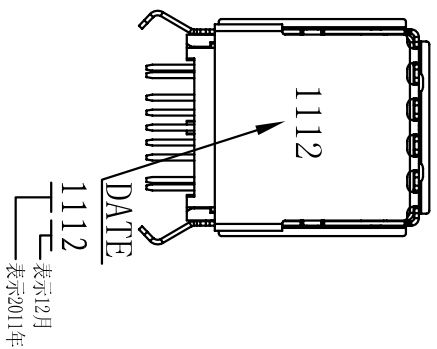
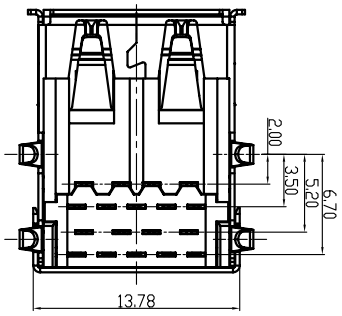
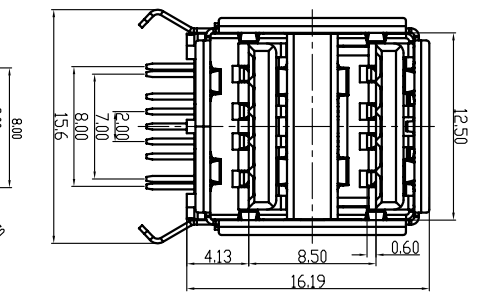
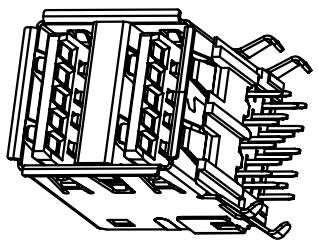
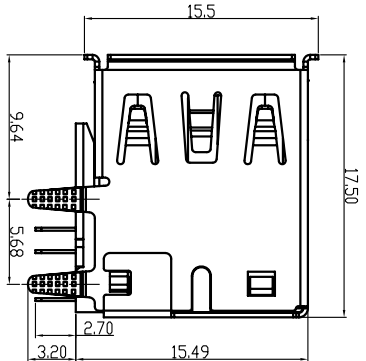
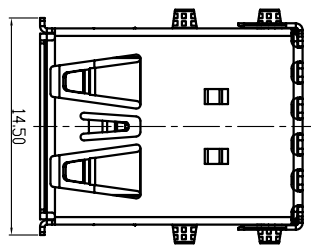

Remark:

- 1.MATERIAL:
  - 1.1 Housing:thermoplastic plastics.
  - 1.2 terminals:Copper Alloy
  - 1.3 Front Shell:Copper Alloy/SPCC.
- Middle Shell:SPCC

2.characteristics:

- 2.1 Rating Voltage : 30V AC.
- 2.2 Rating Current:PIN1&PIN4(Vbus&Corresponding ground PIN) 1.8A MAX Other PINS 0.25A min.
- 2.3 Contact Resistance:PIN1&PIN4:30 mΩ MAX. Other PINS: 50 mΩ
- 2.4 Insulation Resistance:100 MΩ MIN.
- 2.5 Withstanding Voltage:AC 100V between adjacent contacts
- 2.6 Mating force: 3.57Kgf MAX(35N MAX)
- 2.7 Extraction force:1Kgf Min(9.8N Min)
- 2.8 Life test:1500Cycles MIN.
- 2.9 Temperature Range: -30°C~+80°C.

U321-092X-XXXXXR

- 1:Iron alloy
- Ni plating
- 5:Copper alloy
- Ni plating
- 1:Au 1u"
- 3:Au 3u"
- 5:Au 5u"
- 7:Au 10u"
- 8:Au 15u"
- A:Au 30u"
- 1:PA66
- 2:PBT
- 6:LCP
- 1:1:troly
- 2:Tube
- 8:Tape&Reel
- 9:Tape&Reel+Mylar
- 1:Black
- 7:Blue 300C
- 8:Blue 300C-1
- C:Blue 300C-2
- E:Blue 300C-3
- 9:Carbon black425C

深圳市虹康科技有限公司

TOLERANCE UNLESS OTHERWISE SPECIFIED	XXX ±0.10	X ±3
	XX ±0.25	X ±2
	X ±0.35	X ±2

PART NAME: USB 3.0 AF双孔90度短体

CHECKED: pengchenyong

DRAWN: pengchenyong

DATE: 2014.09.30

