

REV.	ECN. NO.	APPD.
A	/	pcy

Remark:

1. MATERIAL:

- 1.1 Housing:thermoplastic plastics.
- 1.2 terminals:Copper Alloy
- 1.3 Front Shell:Copper Alloy/SPCC.
Middle Shell:SPCC

2. characteristics:

- 2.1 Rating Voltage : 30V AC.
- 2.2 Rating Current:PIN1&PIN4(Vbus&Corresponding ground PIN)
- 2.3 Contact Resistance:PIN1&PIN4:30 mΩ MAX. Other PINS: 50 mΩ
- 2.4 Insulation Resistance:100 MΩ MIN.
- 2.5 Withstanding Voltage:AC 100V between adjacent contacts
- 2.6 Mating force: 3.57Kgf MAX(35N MAX)
- 2.7 Extraction force:1Kgf Min(9.8N Min)
- 2.8 Life test:1500Cycles MIN.
- 2.9 Temperature Range: -30℃~+80℃.

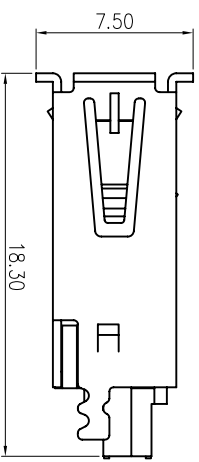
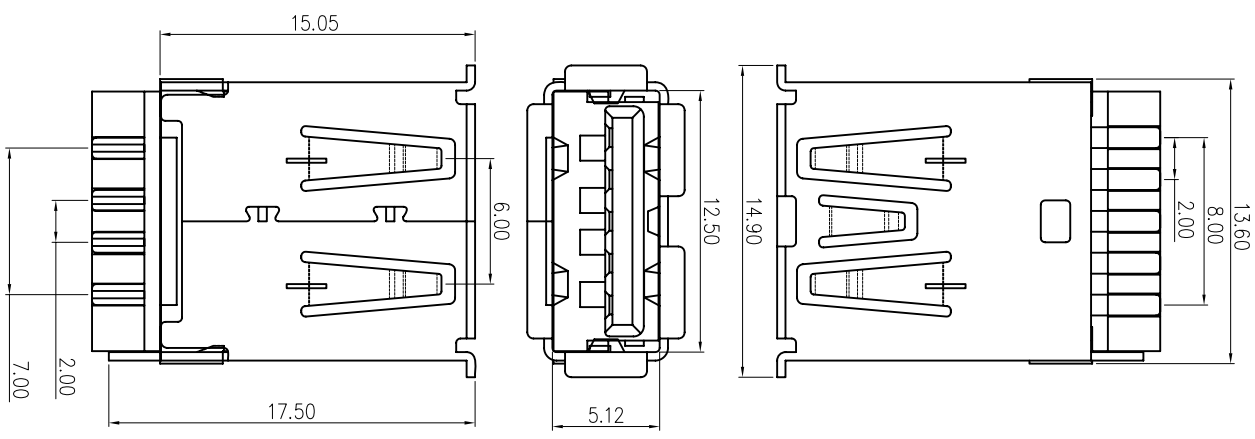

- U325-014X-XXX0XR
- 1:Iron alloy
 - Ni plating
 - 5:Copper alloy
 - Ni plating
 - 1: Au 1u"
 - 3: Au 3u"
 - 5: Au 5u"
 - 7: Au 10u"
 - 8: Au 15u"
 - A: Au 30u"
 - 1: tray
 - 2: Tube
 - 8: Tape&Reel
 - 9: Tape&Reel+Mylar
 - 1: Black
 - 7: Blue 300C
 - 8: Blue 300C-1
 - C: Blue 300C-2
 - E: Blue 300C-3
 - 9: Carbon black425C

深圳市虹康科技有限公司

TOLERANCE UNLESS OTHERWISE SPECIFIED	
.XXX ±0.10	.X° ±3°
.XX ±0.20	.X° ±2°
.X ±0.30	.X° ±2°

PART NAME: USB 3.0 AF 焊线式

APPROVED		PART No.:	SHK-30137	C
CHECKED		PROJECTION:		
DRAWN	pengchaoyong	UNIT:	SCALE	SHEET
DATE	2014.09.29	mm	1:1	1 OF 1