

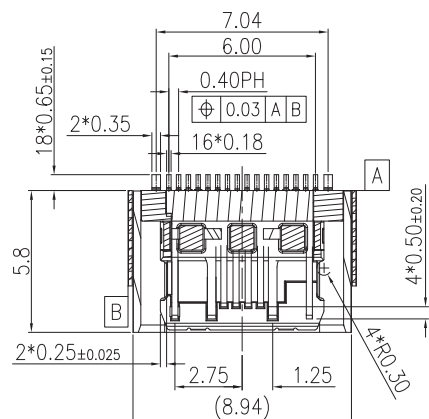

REVISION			
LTR	DESCRIPTION	DATE	APP
1	RELEASE	2016.08.02	Jackson
2	ADDED P/N	2017.01.17	Jackson
3	MODIFY THE CAP	2017.03.30	Jackson

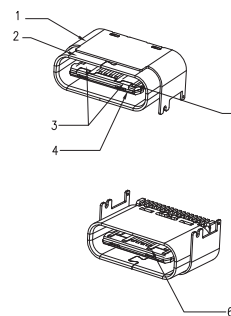

SECTION A-A
SCALE 1:1



- NOTES:
- ELECTRICAL:
 - CONTACT CURRENT RATING 5.0A FOR VBUS AND GND(PINS A4 A9 B4 B9)
 - INSULATION RESISTANCE: 100 MEGAOHMS MIN. AT 250VDC.
 - DIELECTRIC WITHSTANDING VOLTAGE: 100VAC MIN.
 - LOW CONTACT RESISTANCE: INITIAL 40mΩ MAX. AFTER 50mΩ MAX.
 - MECHANICAL CHARACTERISTICS:
 - INSERTION FORCE: 5N~20N.
 - EXTRACTION FORCE: 8N~20N FORM 1 TO 1000CYCLES. 6~20N FORM 1001 TO 10000CYCLES.
 - DURABILITY: 10,000 MATING CYCLES
 - OPERATING TEMPERATURE: -55°C TO +85°C
 - COPLANARITY: 0.10MAX.
 - PART NUMBER INFORMATION:

PART NUMBER	CONTACT PLATING
199-1163011600	Gold flash
199-116305160R	Au 5u"
199-1163101600	Au 10u'
199-1163151600	Au 15u'
199-1163301600	Au 30u'

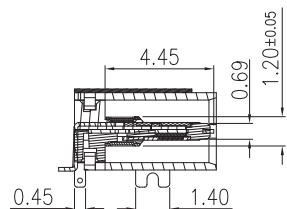

SECTION B-B
SCALE 1:1

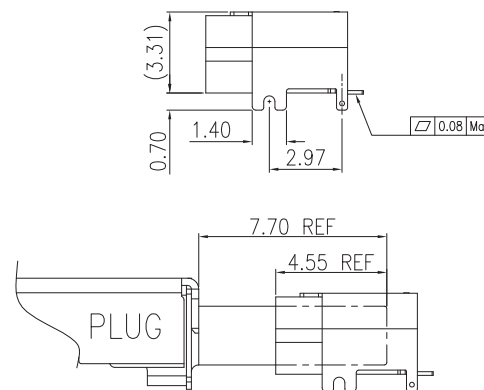
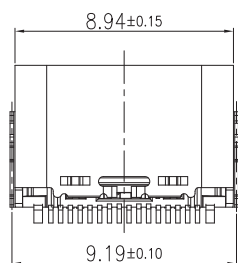
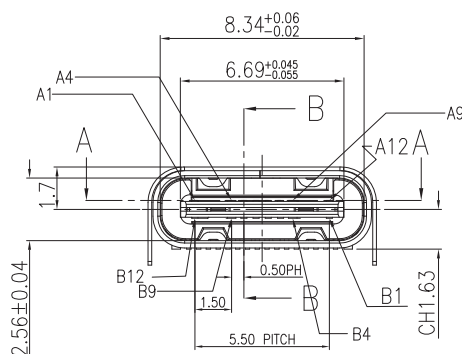

MATING INTERFACE

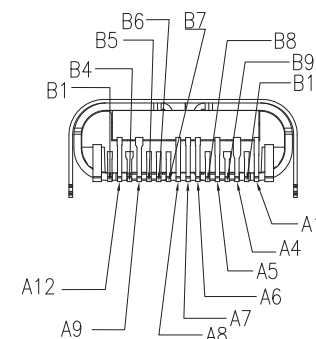

TABLE

ITEM	PART NAME	QTY	MATERIAL	REMARK
1/2	SHELL	2PCS	STAINLESS	NICKEL PLATED 50u" MIN. OVER ALL CLEAN
3	INSERT HOUSING	2PCS	PA10T	UL94V-0
4	Mid-PLATE	1PCS	STAINLESS	NI PLATED 50u" MIN. OVER ALL
5	TOP CONTACT	1SET	COPPER ALLOY	NI UNDERPLATED 50 u" MIN OVER ALL; Au 1u" ON SOLDER TAIL;
6	BOTTOM CONTACT	1SET	COPPER ALLOY	Gold Flash'or 5u"or 10u"or15u"or 30u" ON CONTACT AREA.

TOLERANCE TABLE	
.X	± 0.15
.XX	± 0.10
.XXX	± 0.05
ANGLE	± 2°

				MODEL
深圳市旺康科技有限公司				TYPE C 16PIN
PART NAME	ASSEMBLY			
PART NO.	SEE NOTES			APPROVED Jackson
				CHECKED
MATERIAL	SEE TABLE	SCALE	1:1	DRAWING Jackson
FINISH	SEE TABLE	DATE	2017.03.30	REV 3
THE 3RD PROJECTION		DWG. NO.	P904163-91	SHEET NO. 1/2

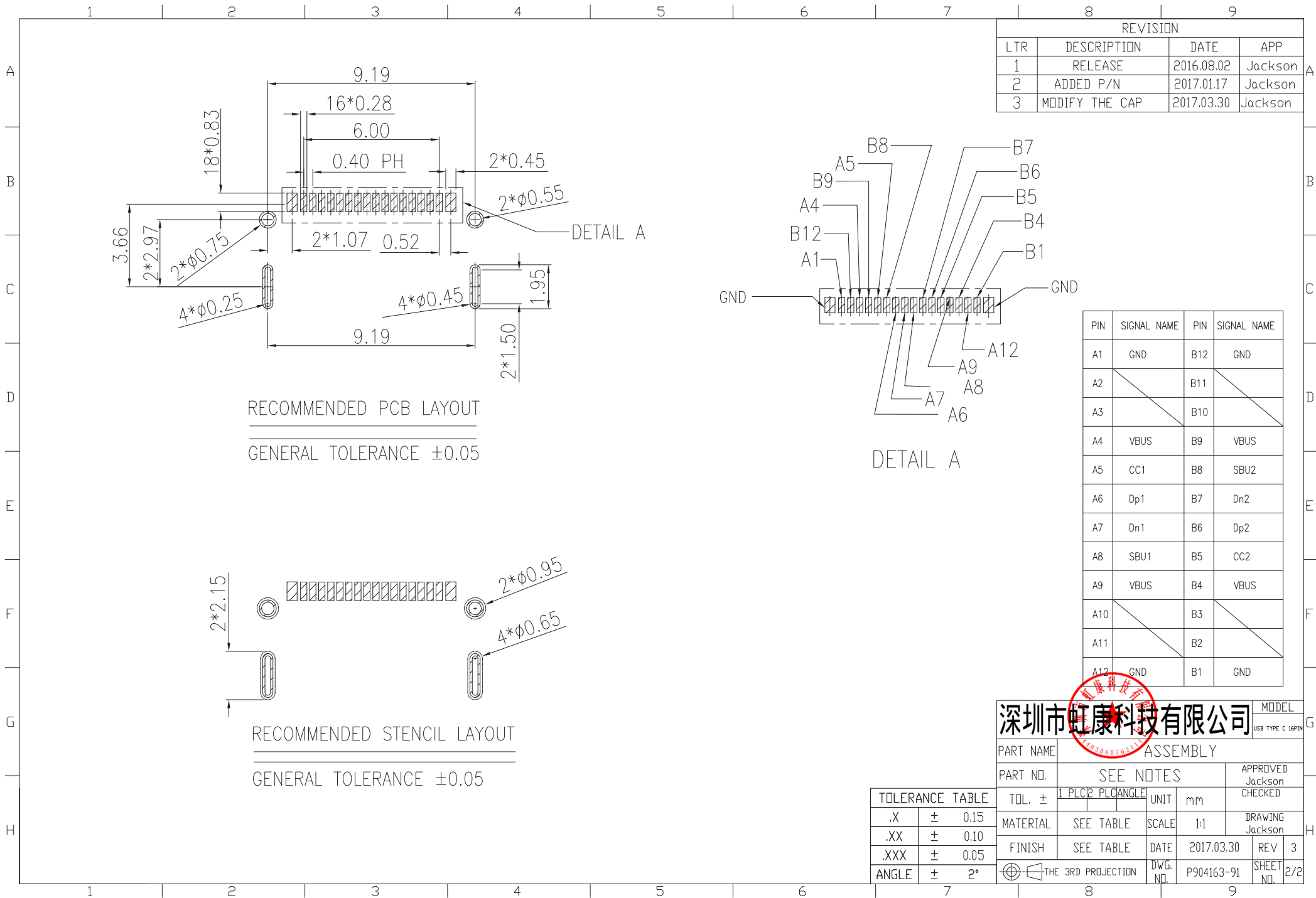

REVISION			
LTR	DESCRIPTION	DATE	APP
1	RELEASE	2016.08.02	Jackson
2	ADDED P/N	2017.01.17	Jackson
3	MODIFY THE CAP	2017.03.30	Jackson

PIN	SIGNAL NAME	PIN	SIGNAL NAME
A1	GND	B12	GND
A2		B11	
A3		B10	
A4	VBUS	B9	VBUS
A5	CC1	B8	SBU2
A6	Dp1	B7	Dn2
A7	Dn1	B6	Dp2
A8	SBU1	B5	CC2
A9	VBUS	B4	VBUS
A10		B3	
A11		B2	
A12	GND	B1	GND

深圳市虹康科技有限公司 MODEL
USB TYPE C 16PIN

PART NAME	ASSEMBLY		APPROVED
PART NO.	SEE NOTES		Jackson
			CHECKED

TOLERANCE TABLE		
TOL.	±	
.X	±	0.15
.XX	±	0.10
.XXX	±	0.05
ANGLE	±	2°

UNIT	mm	DRAWING	Jackson
MATERIAL	SEE TABLE	SCALE	1:1
FINISH	SEE TABLE	DATE	2017.03.30
		REV	3
THE 3RD PROJECTION	DWG. NO.	P904163-91	SHEET NO.
			2/2